

STANDARD SP CLUTCH**SP218P • SP318P****QUALITY IS STANDARD**

- AVAILABLE IN SIZES 11.5" THRU 21.0"
- TAPERED ROLLER MAIN BEARINGS
- OPTIONAL SINTERED IRON PLATES
- OPTIONAL BALL BEARING THROW OUT
- BUILT IN HEX NUT
- CREATES SUITABLE APPLICATION TORQUE CAPACITY
- MORE SUITABLE SIDE LOAD APPLICATIONS
- CREATES 25% HIGHER TORQUE CAPACITY
- ALLOWS FOR MORE FREQUENT ENGAGEMENTS
- EASES ADJUSTMENT VERIFICATION

**SPECIFICATIONS - SP218P & SP318P**

Model Number	SAE HSG.	Max. Input Torque Nm (lb-ft)		Maximum Safe Speed				Weight kg (lbs)
				Solid Plates		Split Plates		
		Organic	Sintered	Cast Drive Ring	Nodular Drive Ring	Cast Drive Ring	Nodular Drive Ring	
SP218P0	0	5427 (4000)	6784 (5000)	1950	N/A	1550	N/A	299 (660)
SP218P00	00							
SP318P0	0	8141 (6000)	10176 (7500)	2050	2350	1550	2100	318 (700)

LOAD CLASSIFICATIONS BASED UPON AGMA LOAD CHARACTERISTICS

PRIME MOVER	DURATION OF SERVICE	DRIVEN MACHINE LOAD CLASSIFICATIONS		
		UNIFORM	MODERATE SHOCK	HEAVY SHOCK
Electric motor	Up to 3 hours per day	1.00	1.25	1.50
	3-10 hours per day	1.00	1.25	1.75
	Over 10 hours per day	1.25	1.50	2.00
Multi-cylinder internal combustion engine	Up to 3 hours per day	1.00	1.25	1.75
	3-10 hours per day	1.25	1.50	2.00
	Over 10 hours per day	1.50	1.75	2.25
Multi-cylinder internal combustion engine with high torque rise	Up to 3 hours per day	1.50	1.75	2.25
	3-10 hours per day	1.75	2.00	2.50
	Over 10 hours per day	2.00	2.25	2.75
Single cylinder internal combustion engine	Up to 3 hours per day	1.25	1.50	2.00
	3-10 hours per day	1.50	1.75	2.25
	Over 10 hours per day	1.75	2.00	2.50

All clutch engagements to be with prime mover below 1000 RPM. High inertia loads may require use of larger clutch. Contact Twin Disc application engineering department for assistance.

TO CALCULATE APPLICATION TORQUE:

$$\frac{5252 \times \text{HP}}{\text{Engine RPM}} = \text{Torque}$$

$$\text{Torque} \times \text{Load Factor} = \text{Application Torque}$$

Use load factor from chart at left

Specifications subject to change without prior notice in the interest of continual product improvement. Contact your local Twin Disc representative for engineering specifications.



SP218P

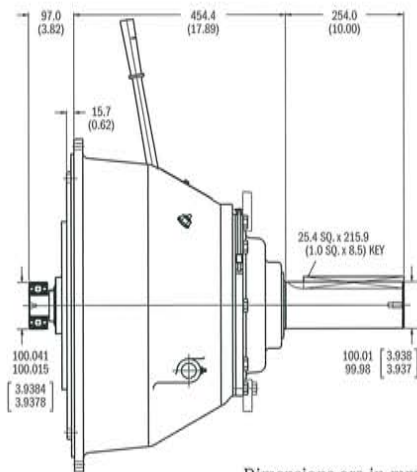

Dimensions are in mm (inches)

SP318P

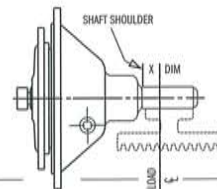
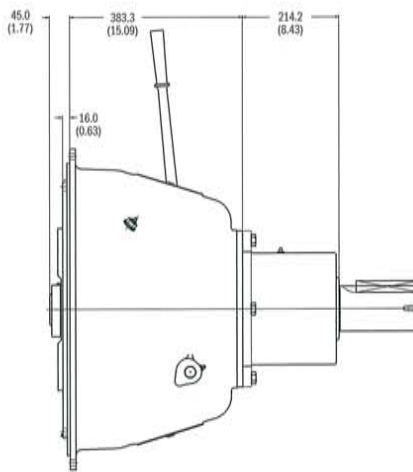

SP218P & SP318P - ALLOWABLE SIDE LOAD, KG (LBS)

PTO MODEL	RPM	X DISTANCE, mm (in) - see sketch									
		25.4 (1.0)	50.8 (2.0)	76.2 (3.0)	101.6 (4.0)	127.0 (5.0)	152.4 (6.0)	177.8 (7.0)	203.2 (8.0)	228.6 (9.0)	
SP218P M2713	1000	4127 (9099)	3947 (8701)	3781 (8336)	3628 (8000)	3360 (7407)	2966 (6539)	2655 (5854)	2403 (5298)	2195 (4839)	
	1200	3909 (8617)	3738 (8240)	3580 (7894)	3436 (7576)	3303 (7283)					
	1800	3461 (7631)	3310 (7297)	3035 (6991)	3043 (6709)	2925 (6450)					2816 (6210)
	2400	3177 (7004)	3038 (6697)	2910 (6416)	2793 (6158)	2685 (5920)					2585 (5699)
SP218P M2327	1000	4127 (9099)	3947 (8701)	3531 (7785)	2990 (6594)	2495 (5720)	2290 (5050)	2050 (4521)	1856 (4092)	1692 (3731)	
	1200	3909 (8617)	3738 (8240)								
	1800	3461 (7631)	3310 (7297)	3035 (6991)							
	2400	3177 (7004)	3038 (6697)	2910 (6416)	2793 (6158)						
SP218P M2977	1000	4127 (9099)	3947 (8701)	3781 (8336)	3628 (8000)	3488 (7690)	3558 (7404)	3146 (6937)	2848 (6278)	2600 (5734)	
	1200	3909 (8617)	3738 (8240)	3580 (7894)	3436 (7576)	3303 (7283)	3180 (7012)	3066 (6760)			
	1800	3461 (7631)	3310 (7297)	3035 (6991)	3043 (6709)	2925 (6450)	2816 (6210)	2715 (5987)	2621 (5779)	2533 (5585)	
	2400	3177 (7004)	3038 (6697)	2910 (6416)	2793 (6158)	2685 (5920)	2585 (5699)	2492 (5494)	2405 (5304)	2325 (5126)	
SP318P0	1000	3629 (8000)	3470 (7650)	3329 (7340)	3193 (7040)	3080 (6790)	2962 (6530)	2776 (6120)	2531 (5580)	2313 (5100)	
	1200	3447 (7600)	3311 (7300)	3175 (7000)	3039 (6700)	2926 (6450)	2817 (6210)	2722 (6000)			
	1800	3003 (6620)	2880 (6350)	2758 (6080)	2649 (5840)	2359 (5200)	2486 (5400)	2368 (5220)	2282 (5030)	2200 (4850)	

The following general formula should be used for determining the actual applied load: $L = \frac{126,000 \times \text{HP}}{N \times D} \times F \times \text{LF}$

- WHERE
- L = Actual Applied Load (lbs)
 - N = Shaft Speed (RPM)
 - D = Pitch Diameter (in) of Sheave, etc.
 - F = Load Factor
 - 1.0 for Chain or Gear Drive, 1.5 for Timing Belts, 2.5 for All V Belts, 3.5 for Flat Belts
 - LF = 2.1 for Reciprocating Compressors and other Severe Shock Drives and 1.8 for Large Inertia Type Drives (i.e. crushers, chippers, planers, etc.)

Compound Drives and Power Engaged Power Take-Off applications must have written factory review.

Twin Disc, Incorporated reminds users of these products that their safe operation depends on use in compliance with engineering information provided in our catalog. Users are also reminded that safe operation depends on proper installation, operation and routine maintenance and inspection under prevailing conditions. It is the responsibility of users (and not Twin Disc, Incorporated) to provide and install guards or safety devices which may be required by recognized safety standards or by the Occupational Safety and Health Act of 1970 and its subsequent provisions.

United States of America • Australia • Belgium • France • Italy • Singapore • Switzerland

For nearly a century, we've been putting horsepower to work by designing, engineering and manufacturing rugged-duty industrial products. Our products and our reputation are bolted to the most renowned engine manufacturers and equipment OEMs in the world. Our mission is to make your machines and vehicles more productive, more durable, more operator-friendly, more cost-effective. From design and installation consultation through after-sale support, Twin Disc and its distributors are committed to your business. No one knows more about managing horsepower in more ways than Twin Disc.

TRANSMISSIONS • CLUTCHES • PTOS
PUMP DRIVES • TORQUE CONVERTERS
GEARBOXES • HYDRAULIC PTO PRODUCTS



Twin Disc, Incorporated
Racine, Wisconsin 53403 USA
Phone +1-262-638-4000
Fax +1-262-638-4488
www.twindisc.com

TD-Bulletin-SP218/318Series
© 2007, Twin Disc, Incorporated
Printed in the USA - 05/2007